



MES6400PHR-8GT4XS Series

DIN-Rail Mounting

Managed Industrial Ethernet Switch

- Support 8 10/100/1000Base-T(X) Ethernet copper ports and 4 10Gigabit SFP+ slots
- Support Precision Time Protocol (PTP), provide sub-microsecond synchronization accuracy to meet requirements for high-precision time synchronization
- Support IEC61850-MMS, ensuring the efficient, reliable and standardized communication between substation devices
- Support MRP ring network, reconfiguration time < 200ms
- High voltage input products support 110VDC or 220VAC/DC; Low voltage input products support 24/48VDC dual power input
- Support -40~75°C wide operating temperature range



Introduction

MES6400PHR-8GT4XS series products are 12-port Gigabit/10Gigabit Ethernet switches. This series supports 8 Gigabit copper ports and 4 10Gigabit SFP+ slots, and adopts DIN-Rail mounting, which is specially designed for extremely severe electromagnetic interference environment to meet the anti-interference requirements of power monitoring industry.

Network management system supports a variety of network protocols and industry standards, such as ARP, IPv4, Ring, MRP, VLAN, STP/RSTP/MSTP, PTP, ERPS, LLDP, IGMP Snooping, QoS, port trunking, port mirroring, etc. It has perfect management functions, supporting port configuration, port statistics, ACL, 802.1X authentication, network diagnosis, rapid configuration, online upgrade, etc. CLI, WEB, Telnet, SNMP, SSH and other access methods can be supported. Network management system could bring you great user experience through its friendly interface design and easy and convenient operation.

DC power supply input consists of two independent power supply circuits, which can ensure device's normal operation when one fails. When power supply or port has link failure, ALM indicator will be bright and send out alarm, meanwhile, alarm device connected to the relay will send out alarm for rapid scene troubleshooting. The hardware adopts fanless, low power consumption and wide temperature and voltage design, which has passed rigorous industrial standard tests, and suits the industrial scene environment with harsh requirements for EMC. It can be widely used in smart substation, smart grid, energy storage, photovoltaic, wind electricity, non-electric industry SCADA system and other industrial fields.

Features and Benefits

- ◎ Precision Time Protocol (PTP), provide sub-microsecond synchronization accuracy to meet requirements for high-precision time synchronization
- ◎ IEC61850-MMS ensures efficient, reliable and standardized communication between substation devices
- ◎ HSR/PRP can realize zero packet loss redundancy of Ethernet and make the power supply network more secure
- ◎ SNMPv1/v2c/v3 is used for network management of various levels
- ◎ RMON can be used for efficient and flexible network monitoring
- ◎ Port mirroring can conduct data analysis and monitoring, which is convenient for online debugging
- ◎ QoS supports real-time traffic classification and priority setting
- ◎ LLDP can achieve automatic topology discovery, which is convenient for visual management
- ◎ File management is convenient for rapid configuration and online upgrading of the

device

- ⦿ Log management records Console log, RAM log and Flash log
- ⦿ Bandwidth management can reasonably distribute network bandwidth, preventing unpredictable network status
- ⦿ Port statistics can be used for the port real time traffic statistics
- ⦿ User password can conduct user hierarchical management to improve the device management security
- ⦿ ACL can enhance network flexibility and security
- ⦿ Relay alarm is convenient for troubleshooting of construction site
- ⦿ Storm suppression can restrain broadcast, unknown multicast and unicast
- ⦿ TELNET configuration and SSH configuration guarantee secure access to data
- ⦿ Port Trunking can increase network bandwidth and enhance the reliability of network connection to achieve optimum bandwidth utilization
- ⦿ IGMP Snooping and static multicast can be used to filter multicast data to save network bandwidth
- ⦿ STP/RSTP/MSTP/Ring/MRP can achieve network redundancy, preventing network storm
- ⦿ ARP could be used for MAC address resolution
- ⦿ With high reliability and stability, ERPS could avoid broadcast storm caused by data loopback
- ⦿ Network diagnosis and troubleshooting could be conducted via Ping, Traceroute, Cable Diagnosis, SFP Digital Diagnosis

Dimension

Unit: mm

● MES6400PHR-8GT4XS-HV

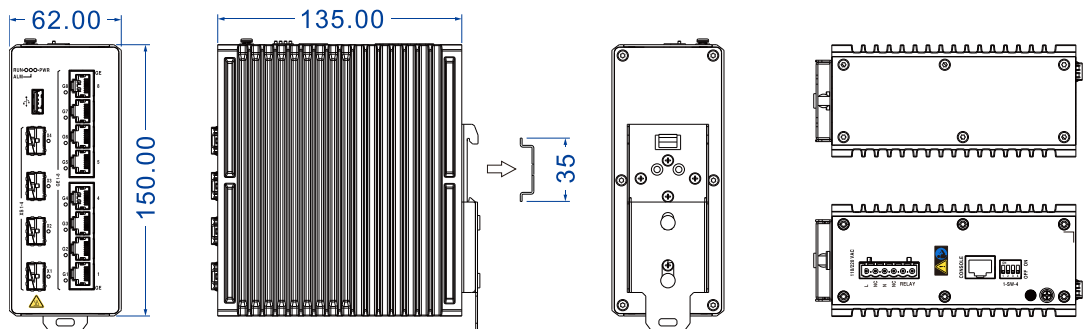

● MES6400PHR-8GT4XS-2LV

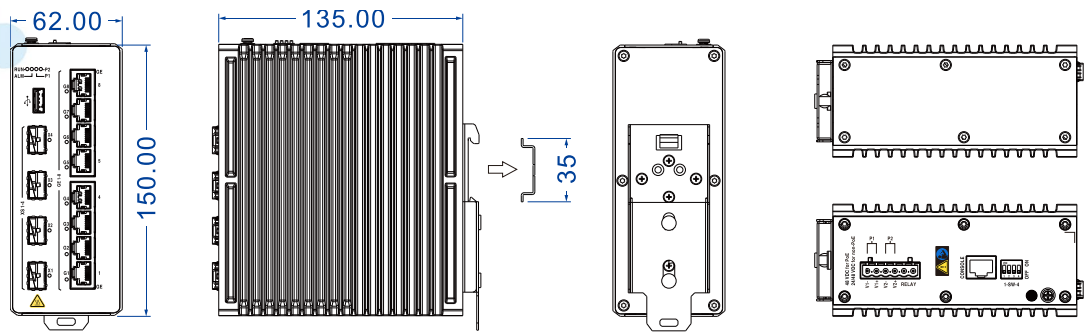

Specification

<p>Standard & Protocol</p>	<p>IEEE 802.3 for 10Base-T IEEE 802.3u for 100Base-TX IEEE 802.3z for 1000Base-X IEEE 802.3ab for 1000Base-T IEEE 802.3ae for 10GBase-X IEEE 802.3x for Flow Control IEEE 802.1D for Spanning Tree Protocol IEEE 802.1w for Rapid Spanning Tree Protocol IEEE 802.1s for Multiple Spanning Tree Protocol IEEE 802.1Q for VLAN IEEE802.1p for CoS IEEE 802.1X for 802.1X Authentication IEEE 802.1AB for LLDP ITU-T G.8032 for ERPS</p>
<p>Management</p>	<p>SNMP v1/v2c/v3 centralized managed equipment, Port Mirroring, Link Flapping Protection, RMON, LLDP, DHCP Server, DHCP Snooping, port statistics, file management, online upgrade, log information, Syslog report, IEC61850 MMS</p>
<p>Security</p>	<p>User authority classification, port and power alarm, MAC security, AAA, 802.1X authentication, RADIUS, TACACS+, MAC-Based authentication, port speed limit, port isolation, port alarm, temperature alarm, DC power alarm, network load alarm</p>
<p>Switch Function</p>	<p>802.1Q VLAN, link aggregation, flow control, ARP, storm control</p>
<p>Unicast / Multicast</p>	<p>Multicast filtering, IGMP Snooping</p>
<p>Redundancy Technology</p>	<p>STP/RSTP/MSTP, ERPS, Ring, MRP, HSR/PRP</p>
<p>Troubleshooting</p>	<p>Ping, Traceroute, Network Cable Diagnosis, SFP Digital Diagnosis</p>

Time Management NTP, PTP

Interface

Gigabit copper port: 8 10/100/1000Base-T(X) copper ports, self-adaption or forced mode, Automatic Flow Control, Full/Half Duplex self-adaption, MDI/ MDI-X Autotuning
10Gigabit SFP+ slot: 4 1G/2.5G/5G/10G Base-X self-adaption or forced mode, SFP+ slot
Console port: CLI command line management port(RS-232), RJ45
USB interface: USB2.0 Type-A(Female), download logs and configuration files, upload configuration files, upgrade software package

Indicator

Running Indicator, Alarm Indicator, Power Supply Indicator, Interface Indicator

Switch Property

Transmission mode: store and forward
MAC address: 32K
Cache: 3Mbit
Backplane bandwidth: 96Gbps
Switch time delay: <10 μ s

Power Supply

MES6400PHR-8GT4XS-2LV:
24/48VDC (18~60VDC), support anti-reverse connection and dual power supply redundancy

MES6400PHR-8GT4XS-HV:
110VDC or 220VAC/DC (85~264VAC/110~300VDC)

Power terminal blocks: 6-pin 5.08mm pitch terminal blocks (power supply occupies 4 pins)

Working Environment

Operating temperature: -40~75 $^{\circ}$ C
Storage temperature:-40~85 $^{\circ}$ C
Relative humidity: 5%~95% (no condensation)

Power Consumption

MES6400PHR-8GT4XS-2LV:
● No-load: 7.4W@48VDC
● Full-load: 14.6W@48VDC
MES6400PHR-8GT4XS-HV:
● No-load: 7.4W@220VAC
● Full-load: 14.6W@220VAC

Mechanical Structure

Installation: DIN-Rail mounting
Dimension (W x H x D): 62mm×150mm×135mm

MES6400PHR-8GT4XS-HV Weight: 1.394kg
MES6400PHR-8GT4XS-2LV Weight: 1.428kg

IEC 61000-4-2 (ESD, electronic static discharge), Level 4

- Air discharge: $\pm 15\text{kV}$
- Contact discharge: $\pm 8\text{kV}$

IEC 61000-4-4 (EFT, electrical fast transient), Level 4

- Power supply: $\pm 4\text{kV}$
- Ethernet interface: $\pm 2\text{kV}$

Industrial Standard

IEC 61000-4-5 (Surge), Level 4

- Power supply: common mode $\pm 4\text{kV}$, differential mode $\pm 2\text{kV}$
- Ethernet port: common mode $\pm 4\text{kV}$, differential mode $\pm 2\text{kV}$

Shock: IEC 60068-2-27

Free fall: IEC 60068-2-32

Vibration: IEC 60068-2-6

Authentication

CE, FCC, RoHS

Warranty

5 years

Ordering Information

Model	Gigabit Copper Port	10 Gigabit SFP+ Slot	Power Supply
MES6400PHR -8GT4XS-2LV	8	4	24/48VDC (18~60VDC)
MES6400PHR -8GT4XS-HV	8	4	110VDC or 220VAC/DC (85~264VAC/110~300VDC)



Address: 3/B, Zone 1, Baiwangxin High Technology Industrial Park, Song Bai Road, Nanshan District, Shenzhen, 518108, China

TEL.: +86-755-26702668 ext 835 FAX: +86-755-26703485

E-mail: ics@3onedata.com

Website: www.3onedata.com

◀ [Please scan our QR code for more details](#)

*Product pictures and technical data in this datasheet are only for reference. Updates are subject to change without prior notice. The final interpretation right is reserved by 3onedata.