

IRT5300L Series Industrial 4G Wireless Router Quick Installation Guide

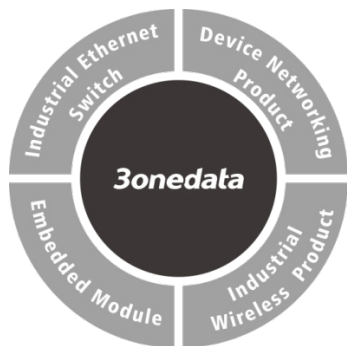

3onedata Co., Ltd.

Address: 3/B, Zone 1, Baiwangxin High Technology Industrial Park, Xili, Nanshan District, Shenzhen

Website: www.3onedata.com

Tel: +86 0755-26702688

Fax: +86 0755-26703485

【Package Checklist】

Please check whether the package and accessories are intact while using the industrial 4G router for the first time.

1. 4G router
2. DIN-Rail mounting attachment
3. WIFI antenna x2
4. LTE antenna x2
5. Power adapter
6. SIM card ejection pin
7. Certification
8. Warranty card

If any of these items are damaged or lost, please contact our company or dealers, we will solve it ASAP.

【Product Overview】

This series product are DIN-Rail industrial 4G routers. For convenience, the products of this series adopt the following number on the left in this guide, please affirm the number of your product.

Model I. IRT5300L-3T2D-2P12_36 (1 100M WAN + 2 100M LAN + 1 RS-232/485/422 + 2 WiFi antennas + 2 LTE antennas)

Model II. IRT5300L-5T2D-2P12_36 (1 100M WAN + 4 100M LAN + 1 RS-232/485/422 + 2 WiFi antennas + 2 LTE antennas)

【Panel Design】

➤ Top view, bottom view and rear view

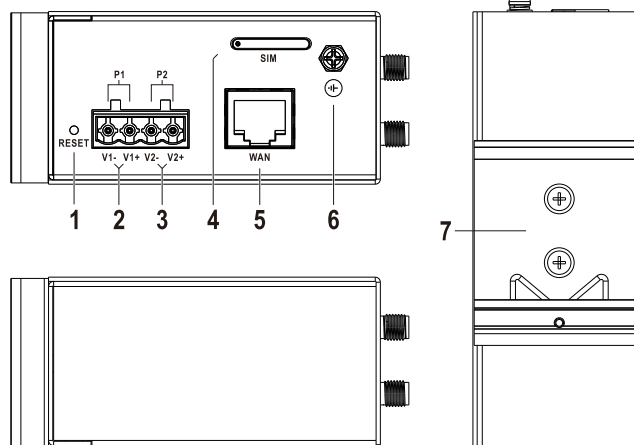

➤ Front view and side view

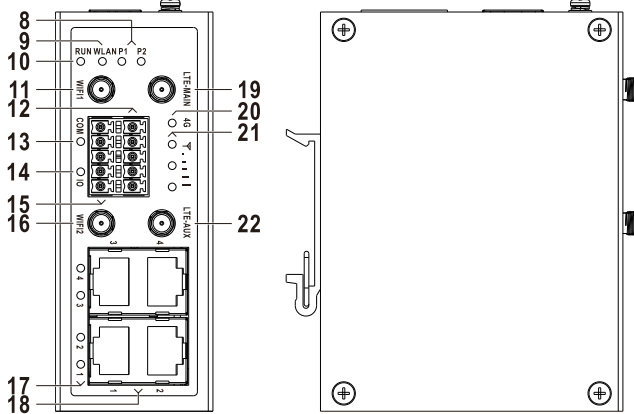

Model II

1. RESET button
2. Input terminal blocks for Power Supply P1
3. Terminal block for Power supply P2 input
4. SIM slot
5. 100M WAN port
6. Grounding screw
7. DIN-Rail mounting kit
8. Power supply indicator (P1-P2)
9. Wireless network indicator (WLAN)
10. Running indicator (RUN)
11. 2.4G WiFi antenna interface (WiFi1)
12. RS-232/485/422 serial port
13. Serial port indicator (COM)
14. IO indicator (IO)
15. IO port (Reserved)
16. 2.4G WiFi antenna interface (WiFi2)
17. LAN port indicator
18. 100M LAN port
19. LTE main antenna interface (LTE-MAIN)
20. 4G LTE indicator
21. LTE signal strength indicator
22. LTE slave antenna interface (LTE-AUX)

【Mounting Dimension】

The external dimensions of this series of products are the same, unit: mm.

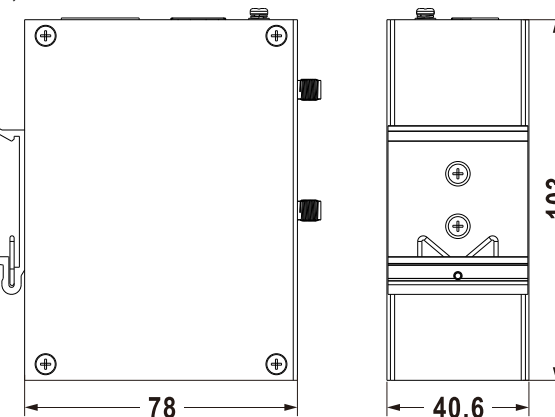

Notice Before Mounting:

- Don't place or install the device in area near water or moist, keep the relative humidity of the device surrounding between 5%~95% without condensation.
- Before power on, first confirm the supported power supply specification to avoid over-voltage damaging the device.
- The device surface temperature is high after running; please don't directly contact to avoid scalding.

【DIN-Rail Mounting】

The product adopts 35mm standard DIN-Rail mounting which is suitable for most industrial scenes, mounting steps as follows:

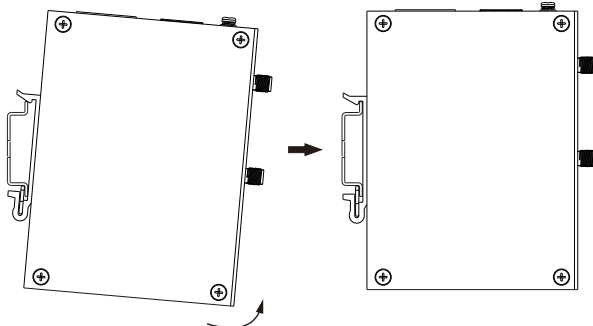

Step 1 Check whether the DIN-Rail mounting kit that comes with the device is installed firmly.

Step 2 Insert the bottom of DIN-Rail mounting kit (one side with spring support) into DIN-Rail, and then insert the top into DIN-Rail.

Tips:

Insert a little to the bottom, lift upward and then insert to the top.

Step 3 Check and confirm the product is firmly installed on DIN-Rail, then mounting ends.

【Disassembling DIN-Rail】

Step 1 Power off the device.

Step 2 After lifting the device upward slightly, first shift out the top of DIN-Rail mounting kit, and then shift out

the bottom of DIN-Rail, disassembling ends.



Notice before power on:

- Power ON operation: First insert the power supply terminal block into the device power supply interface, then plug the power supply plug contact and power on.
- Power OFF operation: First, remove the power plug, then remove the wiring section of terminal block. Please pay attention to the above operation sequence.

【Power Supply Connection】

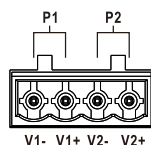

The device provides 4-pin 5.08mm power supply input terminal blocks, and supports P1 and P2 redundant power supply inputs. It could connect to two external power supply inputs, which can ensure the normal operation of the device when one of the systems fails, thus improving the reliability of network operation. The pin definitions of power supply terminal blocks are shown in the left figure, and the power supply input is 12~36VDC.

【Serial Port and IO Ports Connection】

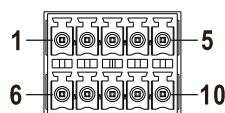

This series of devices provide 1 RS-232/485/422 serial port, 1 IO input and output interface (reserved), and the interface type is 2x5-pin 3.81mm pitch terminal blocks. The pin definitions of interface are shown as follows:

PIN	RS-232	RS-485	RS-422	IO (Reserved)
1	TX	DATA-	T-	—
2	RX	—	R-	—
3	GND	GND	GND	—
4	—	—	—	DI-
5	—	—	—	DO-
6	—	DATA+	T+	—
7	—	—	R+	—
8	GND	GND	GND	—
9	—	—	—	DI+

10	—	—	—	DO+
----	---	---	---	-----

【Reset Button Setting】

This series device provides 1 RESET button, press the button for 1-2s then release it to reboot the device; press the button for 5s then release it to restore factory defaults.

【Mounting SIM Card】

This series device provides 2 SIM slots. It would pops up after you inserting a retrieve card pin in the little hole beside the SIM slot, and then you should put the Micro SIM card in the slot correctly and insert the slot back in the router.



Notes:

If the SIM card needs to be changed, the device should be power off first in case of damaging the card.

【Checking LED Indicator】

The device provides LED indicators to monitor its operating status, which has simplified the overall troubleshooting process. The function of each LED is described in the table below:

LED	Indicate	Description
RUN	ON	The device is powering on or the device is abnormal.
	Blinking	The device is running normally
	OFF	The device is powered off or the device is abnormal.
WLAN	ON	Wireless WiFi network is enabled
	Blinking	Wireless WiFi is in an active network status
	OFF	Wireless WiFi network is running abnormally or turned off
P1-P2	ON	Power supply P1/P2 is connected and running normally
	OFF	Power supply P1/P2 is disconnected or running abnormally
4G	Blinking	LTE module is operating normally

LED	Indicate	Description
	OFF	LTE module isn't operating
T.....	○ ○ ○	All indicators are out. It means the LTE signal of the opposite end is weak or no signal.
	☼ ○ ○	One indicator is on. It means the LTE signal of the opposite end is weak
	☼ ☼ ○	Two indicators are on. It means the LTE signal of the opposite end is normal
	☼ ☼ ☼	All indicators are on. It means the LTE signal of the opposite end is strong
COM	Blinking	The serial port has data being transmitted
	OFF	No serial port connection or no data transfer
IO	—	Reserved
1-2/1-4	ON	LAN port has established valid network connection
	Blinking	LAN port is in network active status
	OFF	LAN port hasn't established a valid network connection
WAN (Green)	ON	WAN port has established valid network connection
	Blinking	WAN port is in network active status
	OFF	WAN port hasn't established valid network connection

【Logging in to WEB Interface】

This device supports WEB management and configuration. Computer can access LAN port of the device via Ethernet interface. The way of logging in to device's configuration interface via IE browser is shown as below:

Step 1 Configure the IP addresses of computer and the

device's LAN port to the same network segment, and the network between them can be mutually accessed

Step 2 Enter device's IP address in the address bar of the computer browser.

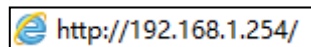

Step 3 Enter device's username and password in the login window as shown below.

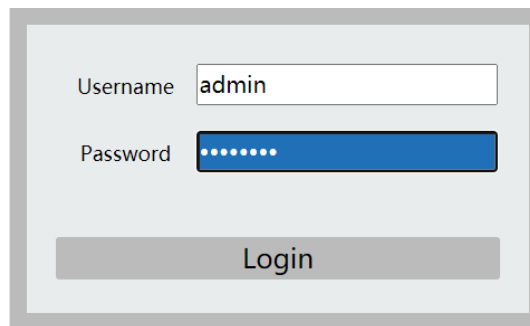

Step 4 Click "Login" button to login to the WEB interface of the device.



Note:

- The default IP address of the device's LAN port is "192.168.1.254".
- The default user name and password of the device are "admin".
- If the user name or password is lost, user can restore it to factory settings via restoring factory setting button; all modified configurations will be cleared after restoring to factory settings, so please backup configuration file in advance.
- Please refer to user manual for specific configuration method of logging in to WEB interface and other configurations about network management function.

【Specification】

Panel	
WAN port	1 10/100Base-T(X) RJ45 port
LAN port	2 or 4 10/100Base-T(X) RJ45 ports
Serial Port	RS-232/485/422, with 2x5-pin 3.81mm pitch terminal (occupies 6 pins)
10 Ports	Reserved
SIM slot	2 SIM slots, redundancy backup, support Micro SIM card
Antenna interface	2 LTE antenna interfaces, SMA-K(Female) <ul style="list-style-type: none"> • Master antenna is used for sending/receiving information • Slave antenna is used for receiving information
	2 WIFI antenna interfaces, RP-SMA-K(Female)
Indicator	Running indicator, WLAN indicator, power indicator, LTE signal strength indicator, 4G indicator, LAN/WAN port indicator, COM indicator and IO indicator
WIFI Transmission Rate	
802.11n	6.5~300Mbps
802.11b	11/5.5/2/1Mbps
802.11g	54/48/36/24/18/12/9/6Mbps
WIFI RF	
Channel	2.412GHz~2.4835GHz
RF power output	20dBm
Modulation system	DBPSK, DQPSK, CCK, OFDM, 16-QAM, 64-QAM
WIFI Receiving Sensitivity	
802.11n_HT40	-82dBm@MCS0, -64dBm@MCS7
802.11n_HT20	-85dBm@MCS0, -67dBm@MCS7
802.11g	-91dBm@6Mbps, -72dBm@54Mbps

802.11b	-93dBm@1Mbps, -87dBm@11Mbps
WIFI Transmission Power	
802.11n_HT40	20dBm@MCS0, 20dBm@MCS7
802.11n_HT20	20dBm@MCS0, 20dBm@MCS7
802.11g	20dBm@6Mbps, 20dBm@54Mbps
802.11b	23dBm@1Mbps, 20dBm@11Mbps
LTE Operating Frequency Band	
TDD-LTE	Band38/39/40/41
FDD-LTE	Band1/3/5/7/8/20
WCDMA	Band1/5/8
TD-SCDMA	B34/39
EVDO/CDMA1X	BC0
GSM	Band3/8
LTE Bandwidth (downward, upward)	
TDD-LTE	Rel 9 Cat4 TDD-LTE 112Mbps/30Mbps
FDD-LTE	Rel 9 Cat4 FDD-LTE 150Mbps/50Mbps
DC-HSPA+	42Mbps/5.76Mbps
HSPA+	21Mbps/5.76Mbps
UMTS	384kbps/384kbps
EVDO RevA	3.1Mbps/1.8Mbps
EVDO Rev0	2.4Mbps/153.6kbps
TD-HSPA	4.2Mbps/2.2Mbps
TD-SCDMA	2.8Mbps/2.2Mbps
CDMA 1x	153.6kbps/153.6kbps
EDGE	236.8kbps/236.8kbps
GPRS	85.6kbps/85.6kbps
LTE Sensitivity	
GSM	<-108dBm
WCDMA	<-109dBm
TD-SCDMA	<-108dBm

TDD-LTE	<ul style="list-style-type: none"> Band38/39/40: <-100dBm @5MHz BW Band41: <-98dBm @5MHz BW
FDD-LTE	<ul style="list-style-type: none"> Band1: <-100dBm @5MHzBW Band3/8: <-97dBm @5MHzBW Band5: <-98dBm @5MHzBW
CDMA	<-108dBm
EVDO	<-108dBm
Maximum Transmission Power of LTE	
LTE-FDD/TDD	23 ±2dBm
WCDMA	24 +1/-3dBm
TD-SCDMA	24 +1/-3dBm
EVDO/CDMA 1X	24 ±1dBm
GSM850/900	33±2dBm
GSM1800/1900	30±2dBm
Power Supply	
Input power supply	12~36VDC dual input, dual power supply redundancy, non-polarity
Access terminal block	4-pin 5.08mm pitch terminal blocks
Power Consumption	
Model II	No-load: 2.4W@24VDC Full-load: 8.1W@24VDC (high temperature)
Working Environment	
Working temperature	-40~75°C
Storage temperature	-40~85°C
Working humidity	5%~95% (no condensation)
Protection grade	IP40 (metal shell)